



**What's ln^3 All About?
And
Relevance to
Customer Council!**

THE *Open* GROUP

Background

- ❑ Interoperability is an issue for most organizations
 - However interoperability is a big issue
 - Interoperability has many meanings
- ❑ Therefore we need to understand what is really meant by this requirement
 - Use business scenarios
- ❑ The following is our understanding of the interoperability requirement

Business Scenarios

- ❑ A Business Scenario describes:
 - Business process, application or set of applications
 - The business and technology environment
 - The relevant people and computing components
 - The desired outcome of proper execution
- ❑ A good Business Scenario
 - Is “S.M.A.R.T.”
 - Enable the supply side to better understand the needs of the buy side
 - Support the business case for the vendors

What Is Meant by Interoperability

- A useful working definition of interoperability
 - The ability of two or more entities or components to exchange information and to use the information that has been exchanged *“to meet a defined mission or objective”*

Customer Problem Statement

- “I could run my business better if I could gain operational efficiencies improving
 - **the many different business processes of the enterprise**
 - both internal, and
 - spanning the key interactions with suppliers, customers, and partners using
 - **integrated information, and integrated access to that information.”**

Pain Points

- ❑ Lack of effectiveness of business operations
- ❑ Lost opportunity to add value to the business
- ❑ Increasing IT costs
- ❑ Lack of effectiveness of IT
- ❑ Reduced management control
- ❑ Increased operational risk

The Criticality of IT Costs

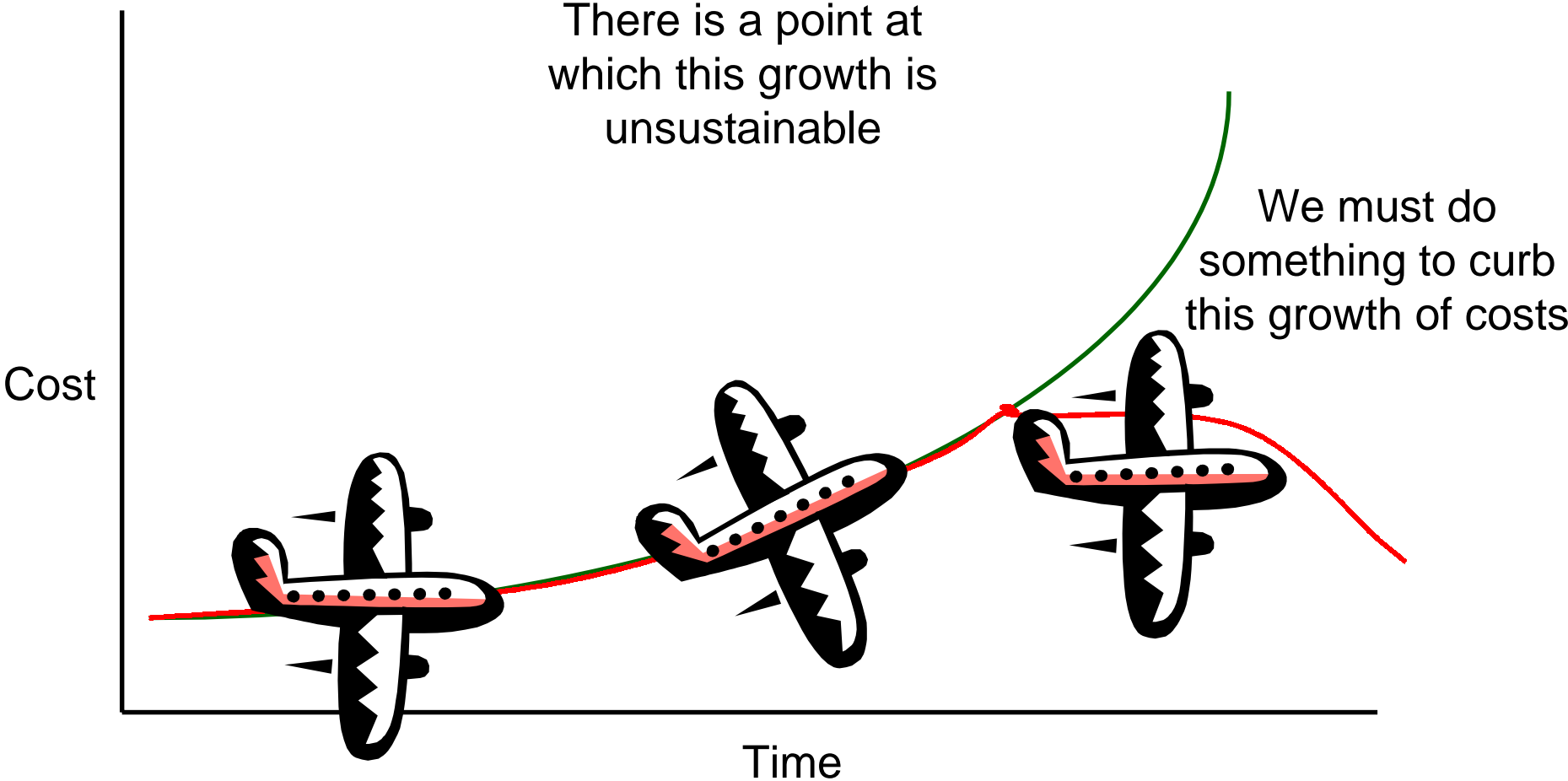

How Important...

- Not having an "Integrated Information Infrastructure" where systems interoperate, i.e. easily exchange information and use that information to improve operations, is causing organizations real pain
 - 100s of millions in lost opportunities
 - Billions are said to be spent to make systems interoperate or to recover from mistakes
 - *The risks are not only financial but deal with lost lives*
 - *Hospitals, 911/999 systems, Critical infrastructure, Air Traffic Control...*

* respondents to survey taken at conference

Forecasts

- ❑ Gartner Dataquest forecasts Worldwide End-User IT Spending will grow from \$2.7 US *trillion* in 2001 to greater than \$3.0 US *trillion* in 2002 and \$3.4 US *trillion* in 2003
- ❑ The worldwide integration services market, is expected to grow at a 25% compounded annual growth rate between 2001 and 2005 to \$116.5 US *billion* according to IDC
- ❑ Recent CIO magazine survey says companies spend over 35% on integrating systems and processes

Shared Problems

Manufacturing Co 1

Manufacturing Co 2

Manufacturing Co 3

<p>Business Processes Manufacturing Process X...</p> <p>Scheduling Procurement Human resources, ...</p>	<p>Business Processes Manufacturing Process Y...</p> <p>Scheduling Procurement Human resources, ...</p>	<p>Business Processes Manufacturing Process Z...</p> <p>Scheduling Procurement Human resources, ...</p>
<p>Business Logic Manufacturing Logic for X</p> <p>Scheduling Procurement Human resources, ...</p>	<p>Business Logic Manufacturing Logic for Y</p> <p>Scheduling Procurement Human resources, ...</p>	<p>Business Logic Manufacturing Logic for Z</p> <p>Scheduling Procurement Human resources, ...</p>
<p>Business Metadata Manufacturing Metadata for X</p> <p>Scheduling Procurement Human resources, ...</p>	<p>Business Metadata Manufacturing Metadata for Y</p> <p>Scheduling Procurement Human resources, ...</p>	<p>Business Metadata Manufacturing Metadata for Z</p> <p>Scheduling Procurement Human resources, ...</p>
<p>Middleware</p>	<p>Middleware</p>	<p>Middleware</p>
<p>Operating Systems</p>	<p>Operating Systems</p>	<p>Operating Systems</p>
<p>Computer Hardware</p>	<p>Computer Hardware</p>	<p>Computer Hardware</p>
<p>Networks</p>	<p>Networks</p>	<p>Networks</p>

Common problems

Shared Problems across Industries

Manufacturing	Finance	Petrochemicals
Business Processes Manufacturing... Scheduling Procurement Human resources, ...	Business Processes Banking... Scheduling Procurement Human resources, ...	Business Processes Exploration... Scheduling Procurement Human resources, ...
Business Logic Manufacturing Scheduling Procurement Human resources, ...	Business Logic Banking... Scheduling Procurement Human resources, ...	Business Logic Exploration... Scheduling Procurement Human resources, ...
Business Metadata Manufacturing Scheduling Procurement Human resources, ...	Business Metadata Banking... Scheduling Procurement Human resources, ...	Business Metadata Exploration... Scheduling Procurement Human resources, ...
Middleware	Middleware	Middleware
Operating Systems	Operating Systems	Operating Systems
Computer Hardware	Computer Hardware	Computer Hardware
Networks	Networks	Networks

Common problems

Problems from ...

*Need to integrate
and optimize
business
processes*

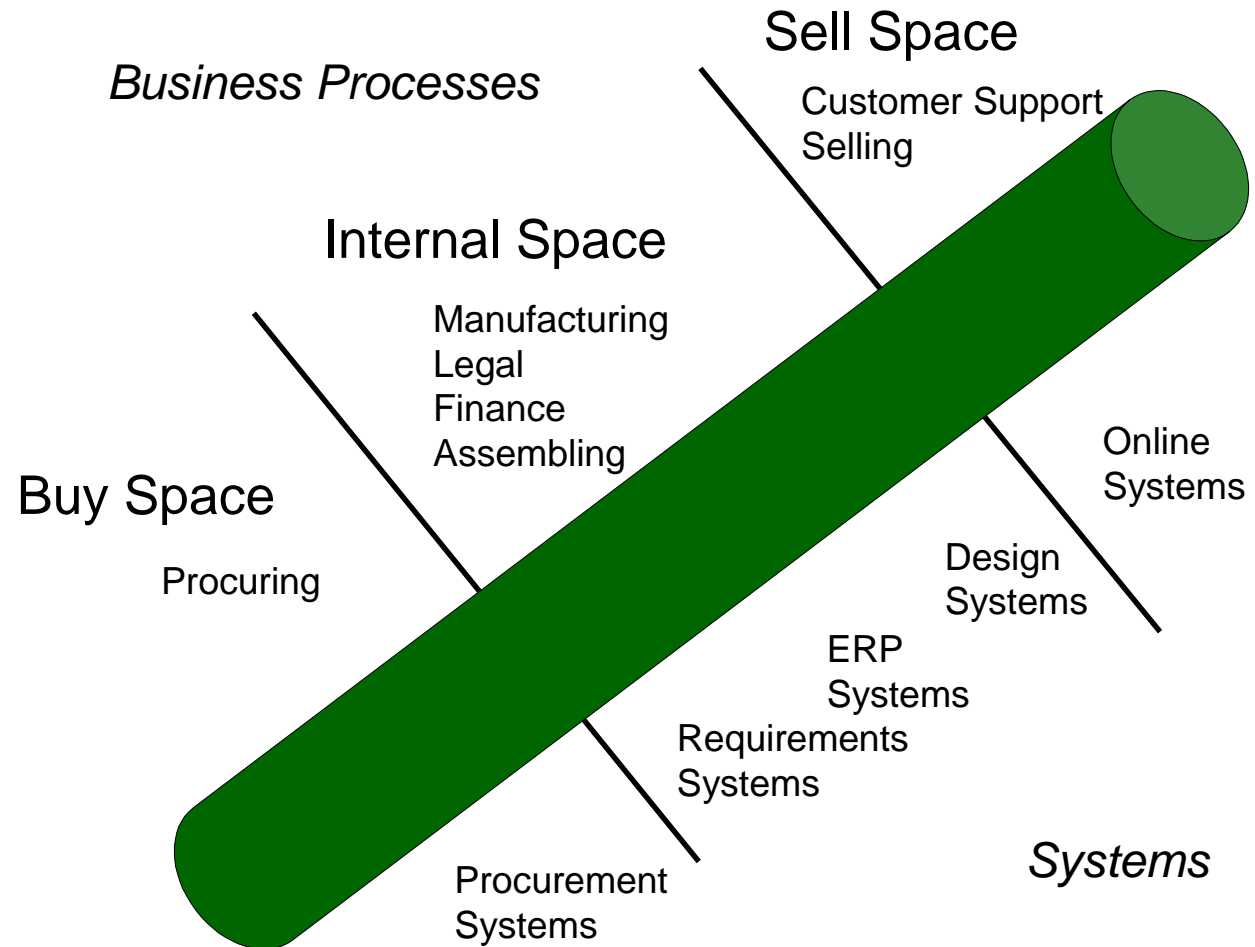

Problems from ...

However fundamental issues are:

*Integrated information
and
Integrated access*

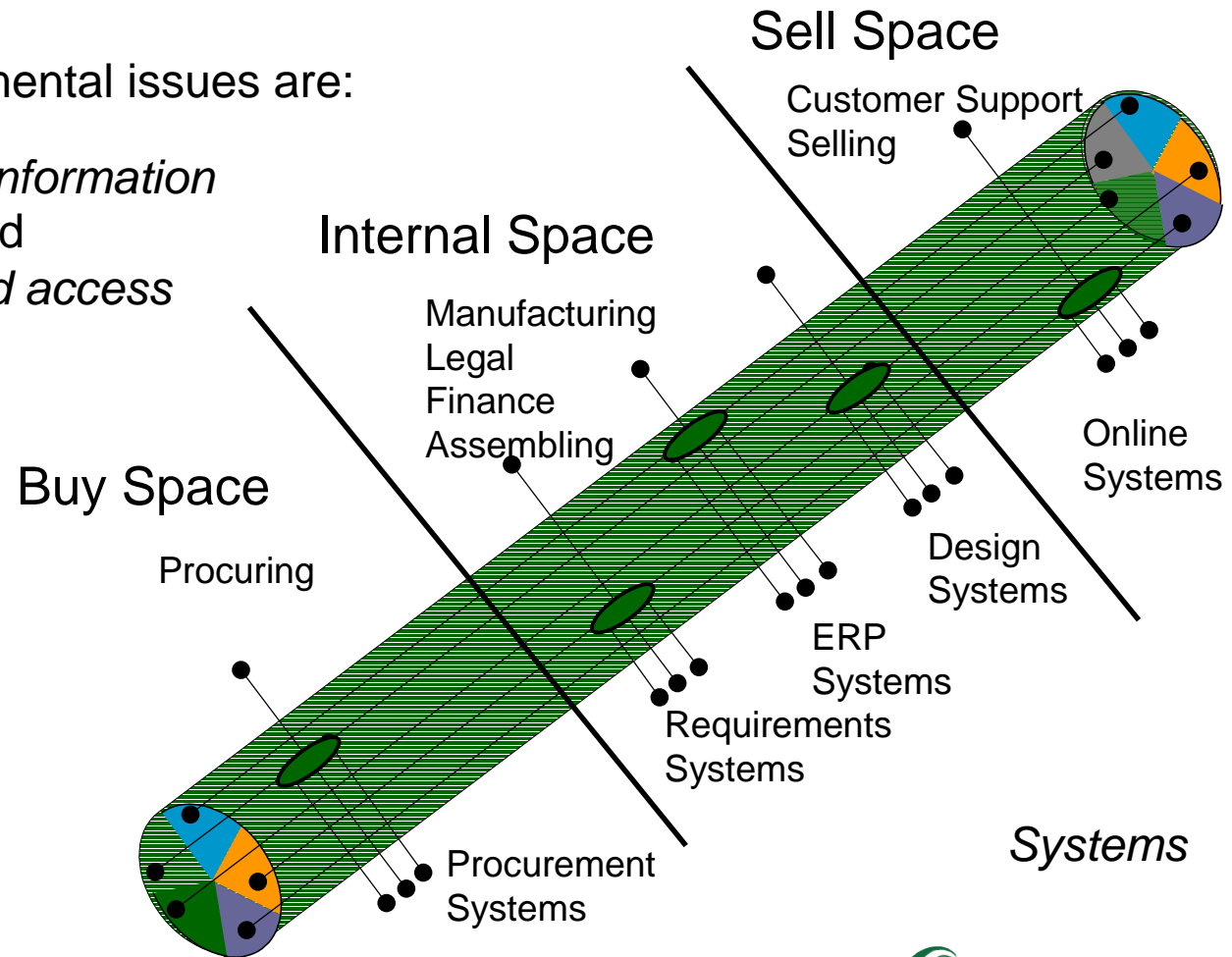

Need for Integrated Access

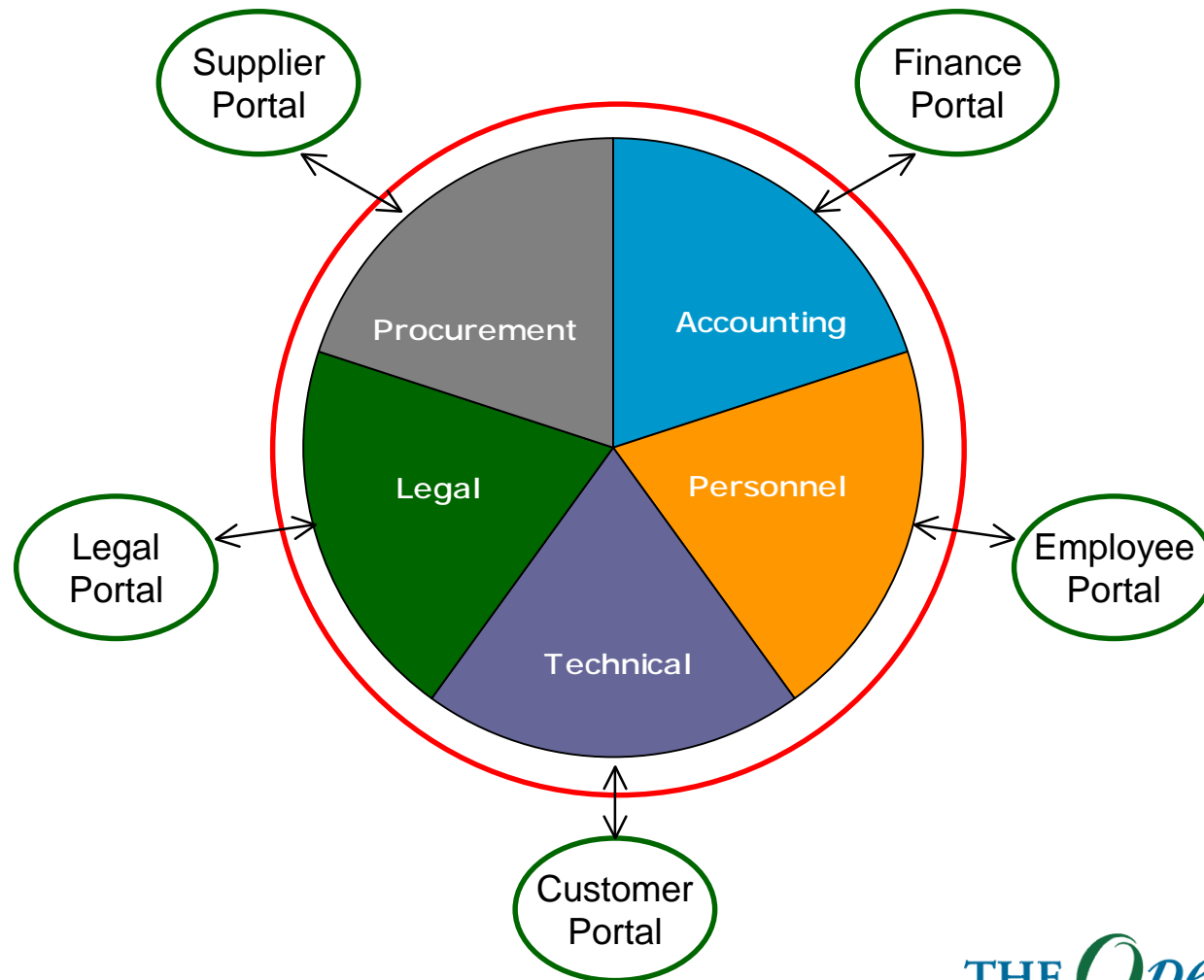

Business Environment

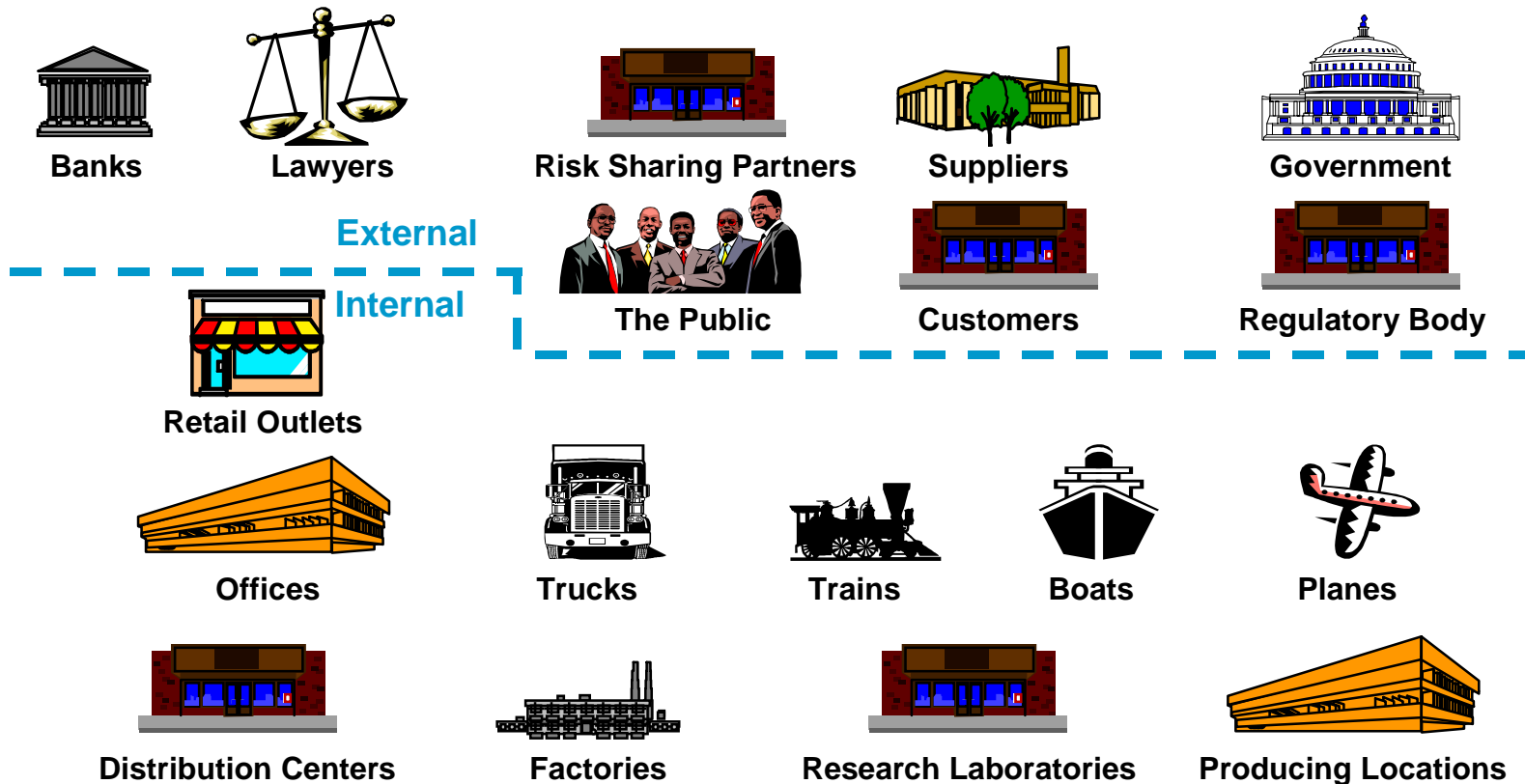

Business Environment

Extending the Reach

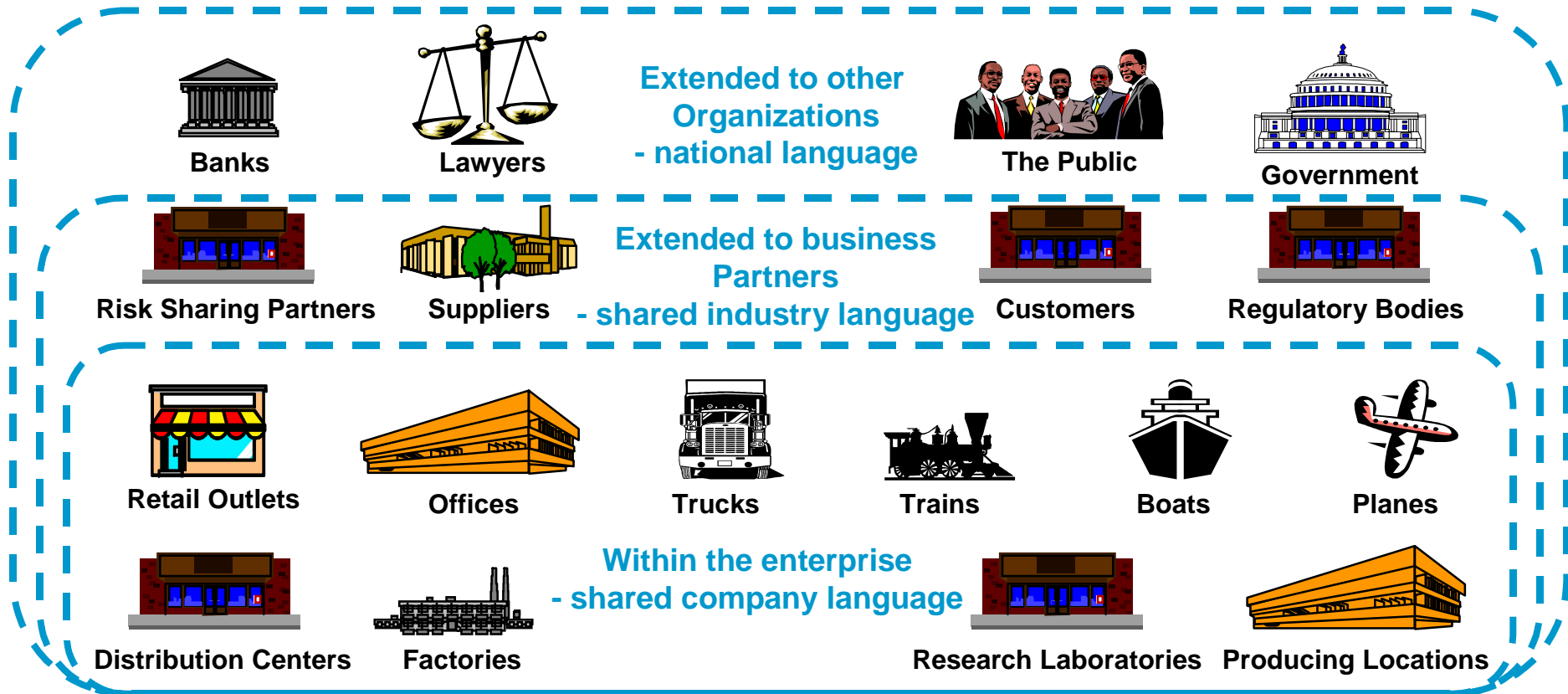

Business Environment

(product lifecycle)

- ❑ Internal processes include processes like:
 - Product definition
 - Manufacturing process design and definition
 - Inbound logistics
 - Workflow / shop floor logistics
 - Outbound logistics (fulfillment/delivery)
 - Maintenance, and
 - Discontinuance

Success is measured in terms of process efficiency and accuracy!

Examples of Human Actors

- ❑ Clerks
- ❑ Analysts
- ❑ Engineers
- ❑ Materials acquisition and procurement specialists
- ❑ Shipping and delivery personnel
- ❑ Researchers
- ❑ Security specialists
- ❑ Suppliers
- ❑ Shop floor workers and technicians

People executing processes are **always** in the value chain!

Business Environment

Consider a "Product Lifecycle" Example

Simple question, what is the impact of offering internet connectivity on an airplane or in a car?

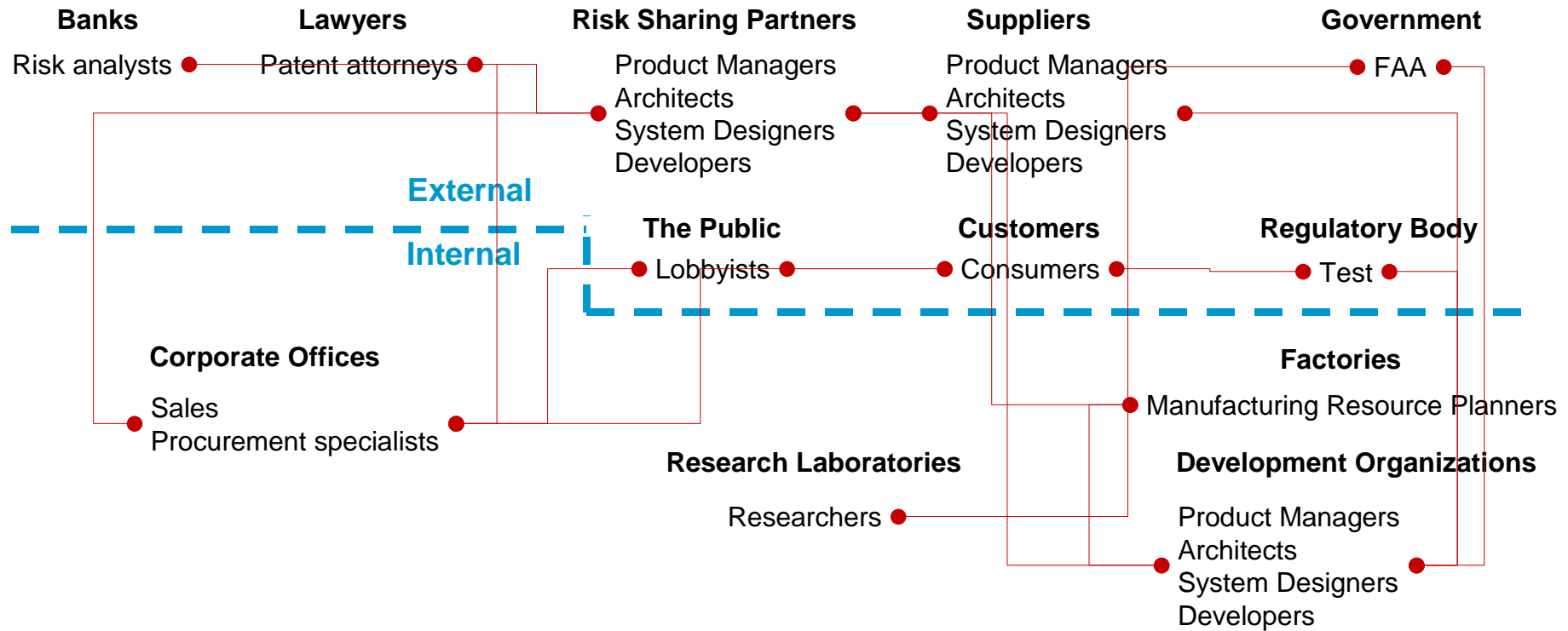

Many people must get engaged, and involves access to much information that requires integration!

Technology Environment

Network View

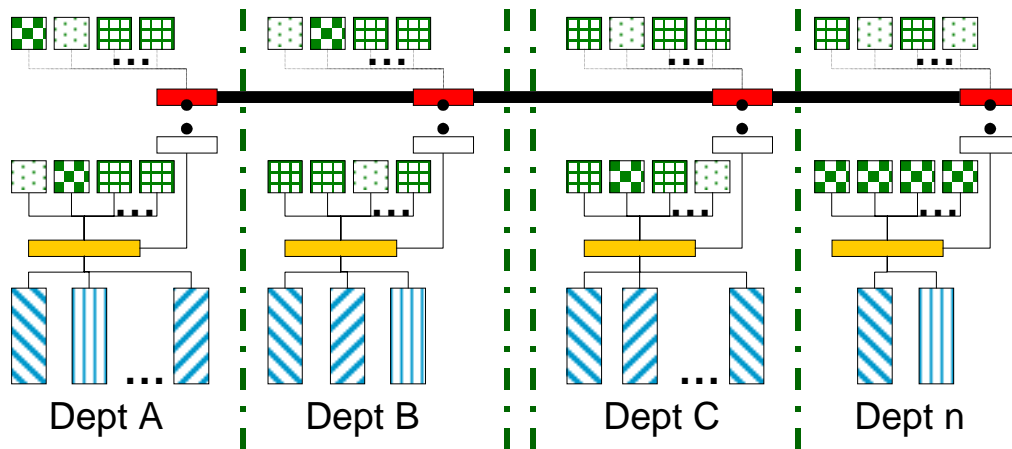

- Highly complex
- Heterogeneous
- 1000s of systems
- Information throughout
- Need for some level of information sharing

- Too much information that just can't be easily accessed and managed!

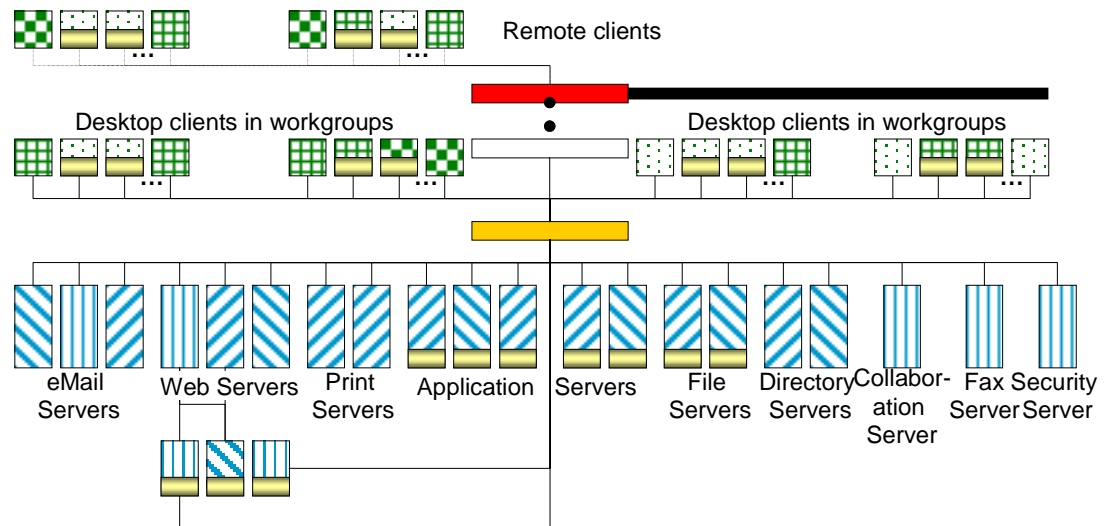

Objectives and Measures

- ❑ Improve business productivity and effectiveness of business operations
 - Improve select process performance metrics
 - Revenue growth
- ❑ Shorter cycles to return on IT investment
 - % of procurements against standards
 - Spend on customizations
- ❑ Improve effectiveness of information technology organization
 - Asset utilization
 - Cycle time for rolling out upgrades
- ❑ Improve service
- ❑ Improve management efficacy
- ❑ Reduce risk

So What Is In³?

- ❑ An ***Integrated Information Infrastructure*** is a desired state for an enterprise's infrastructure specific to the needs of the organization
 - It has standard components that provide services in a customer's extended enterprise that
 - Combine multiple sources of information
 - Deliver information to the places where that information is needed and
 - In the right context for the people or computer components using that information

So What Must One Do...

	Information	Infrastructure
Business	<ul style="list-style-type: none">□ Understand business processes and information<ul style="list-style-type: none">▪ Prioritize and Assess□ Create/adapt policies and best practices<ul style="list-style-type: none">▪ General management guidelines▪ Use, management, and security policy	<ul style="list-style-type: none">□ Identify and prioritize business information flow□ Identify sources of information□ Assess mechanisms for information flow□ Register sources and destinations of information□ Develop business architecture
Technical	<ul style="list-style-type: none">□ Research<ul style="list-style-type: none">▪ Security services▪ Information services▪ Brokering services▪ Integrated access services▪ ...	<ul style="list-style-type: none">□ Plan, develop, test and deploy<ul style="list-style-type: none">▪ Security services▪ Information services▪ Brokering services▪ Integrated access services▪ ...

One Would Have a Lot to Do

- ❑ Takes Time
- ❑ Costs Money
- ❑ Judged on quality and results

Option 1 - Go it Alone

- ❑ Longer elapsed time
- ❑ High costs
- ❑ Unpredictable quality
- ❑ No lasting guarantee
- ❑ High risk

Option 2 - Leverage

- ❑ Shorter elapsed time
- ❑ Greater industry investment
- ❑ Lower organization costs
- ❑ Safety in numbers
- ❑ Safety in certified standard products
- ❑ Shared risk

So What Can You Do In The Open Group?

Information

Infrastructure

Business

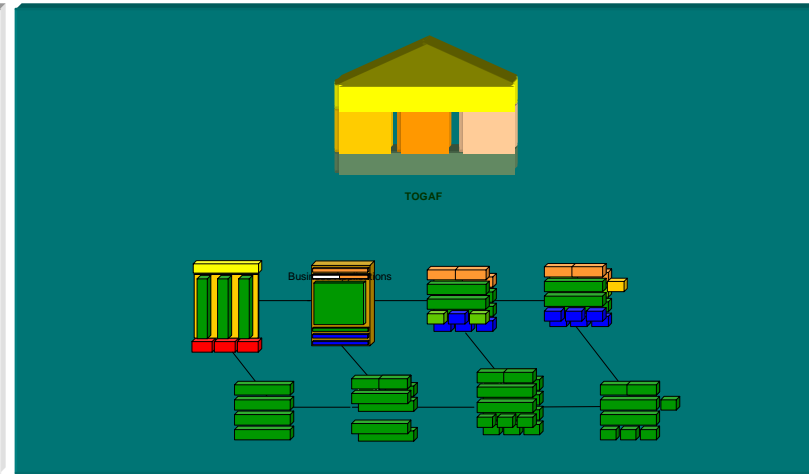

Technical

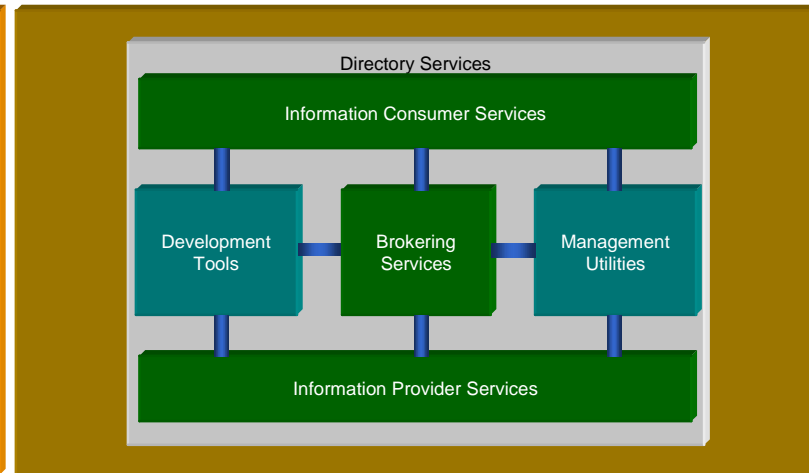

What Else Can We Do?

- ❑ Communicate to CxO levels on the importance of the issue
- ❑ Muster support from major customer and vendor organizations
- ❑ Bring the right organizations together; DMTF, OASIS, OMG, W3C, IETF, ...

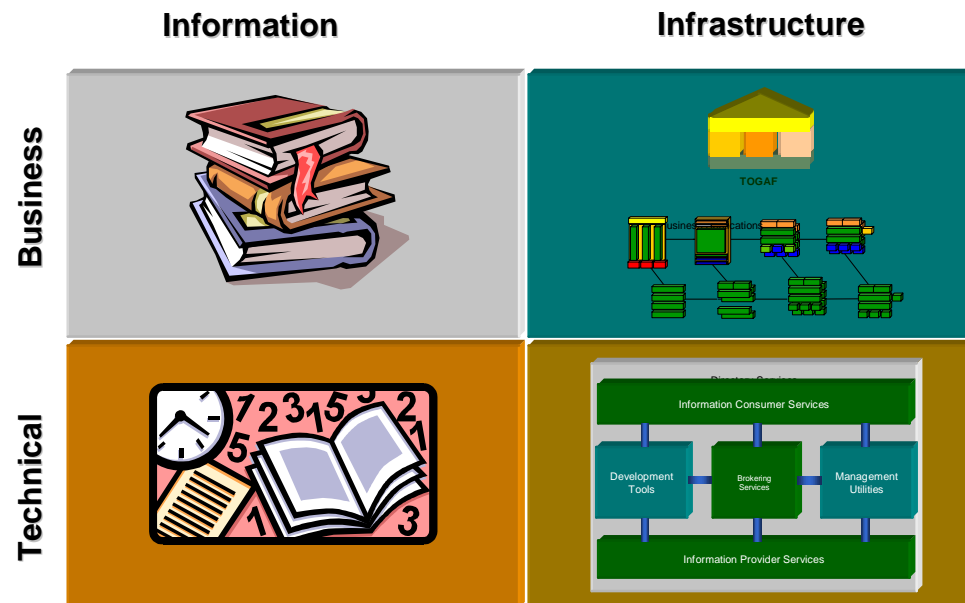

How

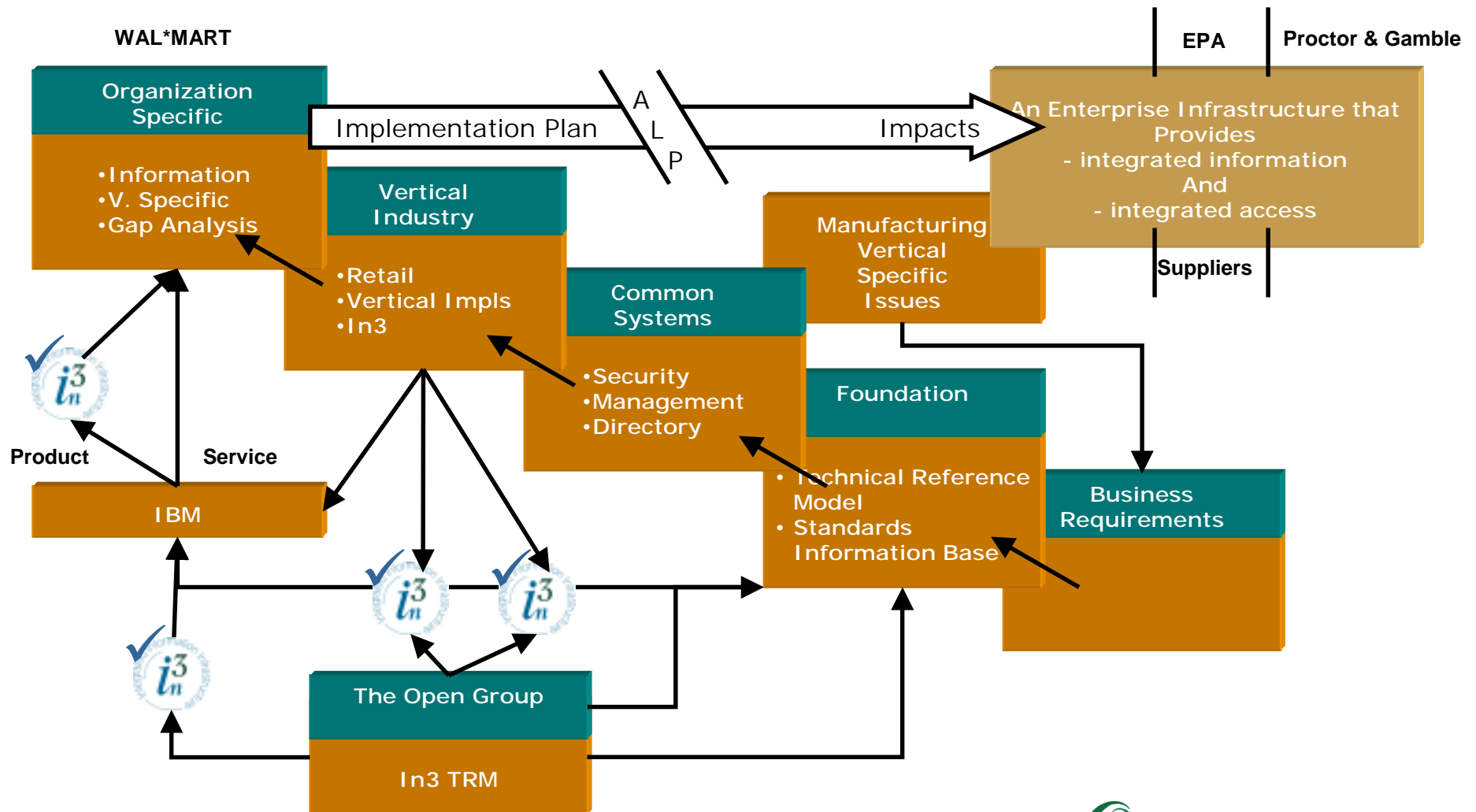

Notes on Architecture Models

- ❑ It is not intended to
 - Create an enterprise architecture that everyone must adopt
- ❑ But rather
 - Establish a technical reference model that could be used in conjunction with something like TOGAF to build one's architecture for one's Integrated Information Infrastructure

A Level 1 Model

(front view)

None of this is cast in concrete!

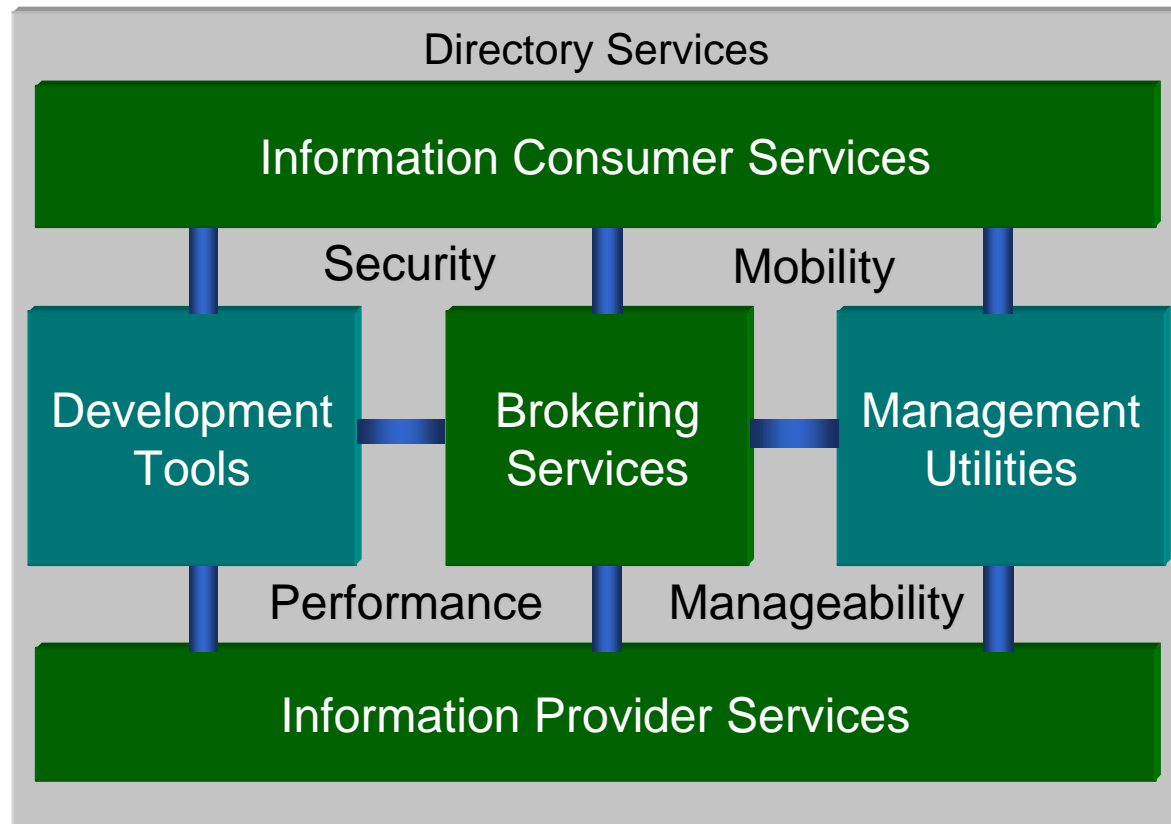

■ Classes of Interfaces - formats and protocols ...

A Level 2 Model

None of this is cast in concrete!

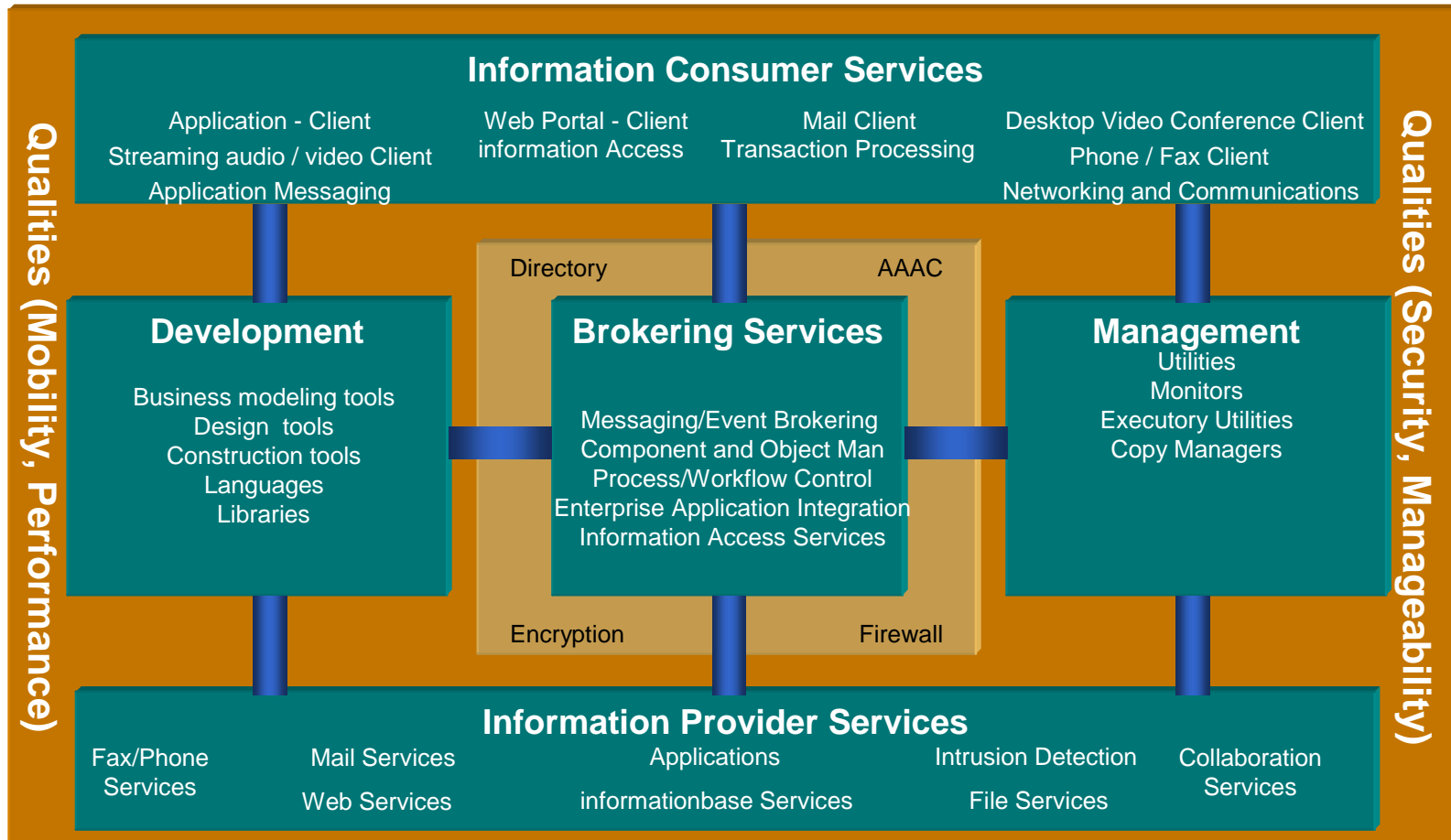

■ Classes of Interfaces - formats and protocols ...

What's the Difference?

- ❑ There are many efforts going on in this space,
 - Global Grid, Global Information Utility, Internet Operating System, etc...
- ❑ Most of these efforts either focus on a particular aspect, or a particular technology
- ❑ The Open Group
 - Is looking at whole problem, bringing together all the parts and pieces
 - Best practices and technology standards
 - Well equipped to be the certification authority: to ensure that the pieces and parts have lasting guaranteed value to the enterprise

Won't it be nice when...

- ❑ The Open Group membership announces the availability of the following profiles that represent collections of standards that can be used to produce products that are certified to interoperate as specified.
- ❑ These profiles represent major building blocks necessary for companies to build their Integrated Information Infrastructures which is estimated to save companies *billions* per year and improve operational efficiencies.

Potential roles

Marketing
& Sales

Customer
Council

Certification
Business

External
Consortia
and Open
Source

For thought and discussion:

- Own the requirements, champion and monitor throughout process.
- Voice issues.
- Sell internally in your organizations.
- Participate in forum through liaisons.
- Help buyers speak with one voice about collective needs.
- Educating business managers and decision-makers on understanding what they need and what they should buy.

CoS

MMF

RT

MSG

We All Have Parts to Play

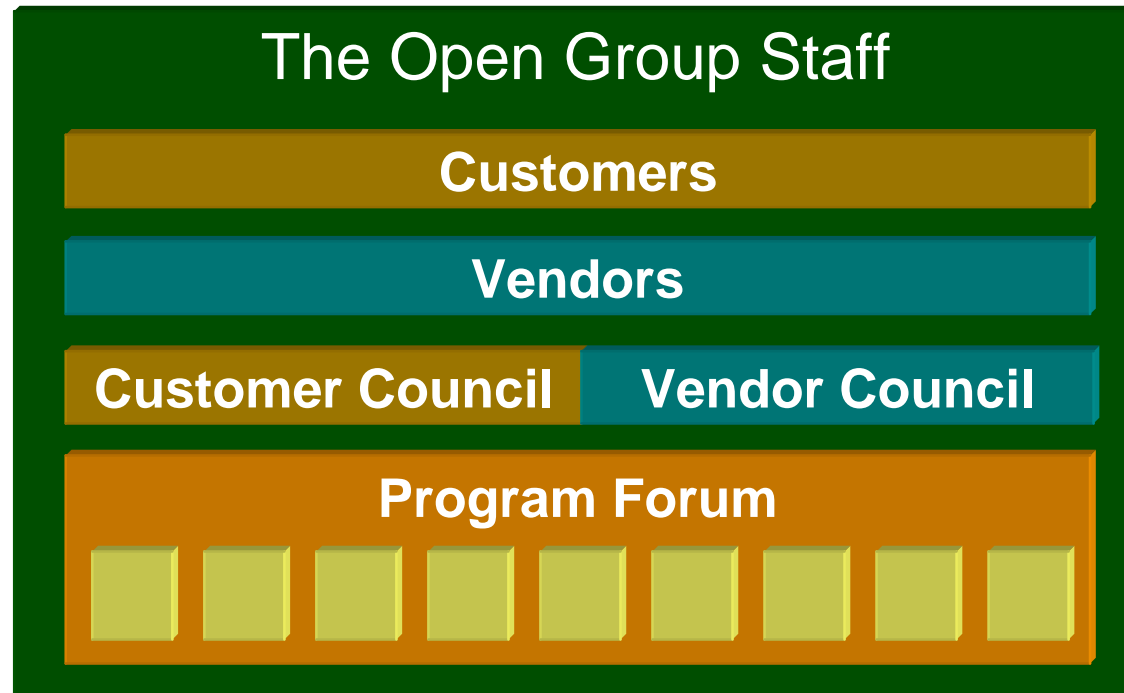

We can and will succeed!
Together we're better.